

BILL OF MATERIALS

MK. NO.	QTY. REQ'D.	DESCRIPTION	SIZE	MATERIAL	REMARKS	LINE NO.	
		LIGHT DUTY SHAFT - L					1
1	1	OCTAGONAL SECTION SHAFT	178 A/F - 153 A/F x 3.083	CSA G40.21 350W		2	
2	1	BASE PLATE	38 x 451 x 451	CSA G40.21 300W		3	
3	1	ARM FLANGE PLATE	25 x 206 x 293	CSA G40.21 300W		4	
4	1	TOP PLATE	6 x 165 x 165	CSA G40.21 300W	SEE DETAIL C	5	
5	2	SIDE PLATES	6 x 110 x 206	CSA G40.21 300W		6	
6	1	TOP GUSSET PLATE	6 x 177 x 177	CSA G40.21 300W		7	
7	1	BOTTOM GUSSET PLATE	6 x 177 x 182	CSA G40.21 300W		8	
8	1	CAP PLATE	6 x 165 x 165	CSA G40.21 300W	SEE DETAIL D	9	
9	4	CAP PLATE BOLT	10 (3/8") DIA. x 38	SAE GR. 5	SEE DETAIL E	10	
10	1	BACK-UP STRIP PLATE	4.554 x 40	CSA G40.21 350W		11	
11	1	PIPE PENETRATION (1 1/2") C/W PLUG	48 O.D. X 25	ASTM A53 GR. B SCH. 40	REMOVE BURRS AND SHARP EDGES	12	
						13	
						14	
						15	
12	1	ACCESS PANEL			SEE NOTE 7		
						16	
13	1	BREAKAWAY BASE ASSEMBLY			SUPPLIED BY OTHERS		

APPROXIMATE TOTAL MASS = 143 kg

NOTES:

- ALL MATERIALS, EXCEPT STAINLESS STEEL ITEMS, SHALL BE HOT DIP GALVANIZED IN ACCORDANCE WITH ASTM A123-09 (PLUS LATEST REVISIONS) WITH NET RETENTION OF 610 g/m².
- PROVIDE RAISED IDENTIFICATION NUMBER WITH WELDING ELECTRODE AS PER SPECIFICATION, STRUCTURE TYPE CODE = L.
- SHIP WITH CAP PLATE C/W NUTS AND WASHERS INSTALLED.
- GRIND ALL SHARP POINTS AND EDGES.
- LONGITUDINAL SEAM WELD SHALL HAVE 60% MINIMUM PENETRATION EXCEPT WITHIN 150 mm OF BASE PLATE AND 400 mm OF TOP PLATE SHALL BE COMPLETE PENETRATION.
- EXTERIOR WELD JOINING SHAFT TO BASE PLATE SHALL BE AN UNEQUAL LEG COMPLETE PENETRATION WELD WITH THE LONG LEG OF THE WELD ALONG THE SHAFT, TERMINATING AT 30" FROM THE SHAFT'S SURFACE.
- PROVIDE ACCESS PANEL IN ACCORDANCE WITH SHEET 17.

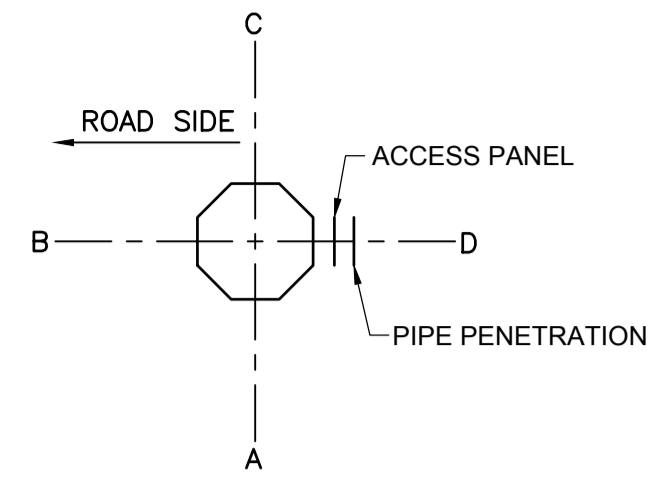

ORIENTATION

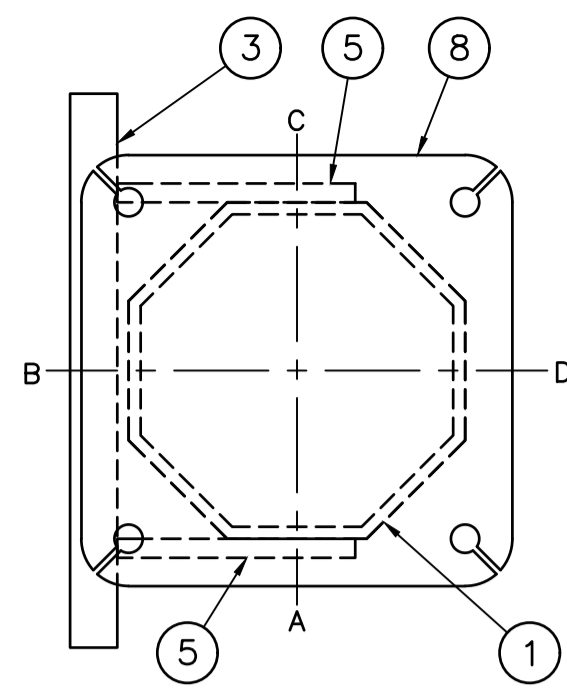

PLAN-TOP VIEW

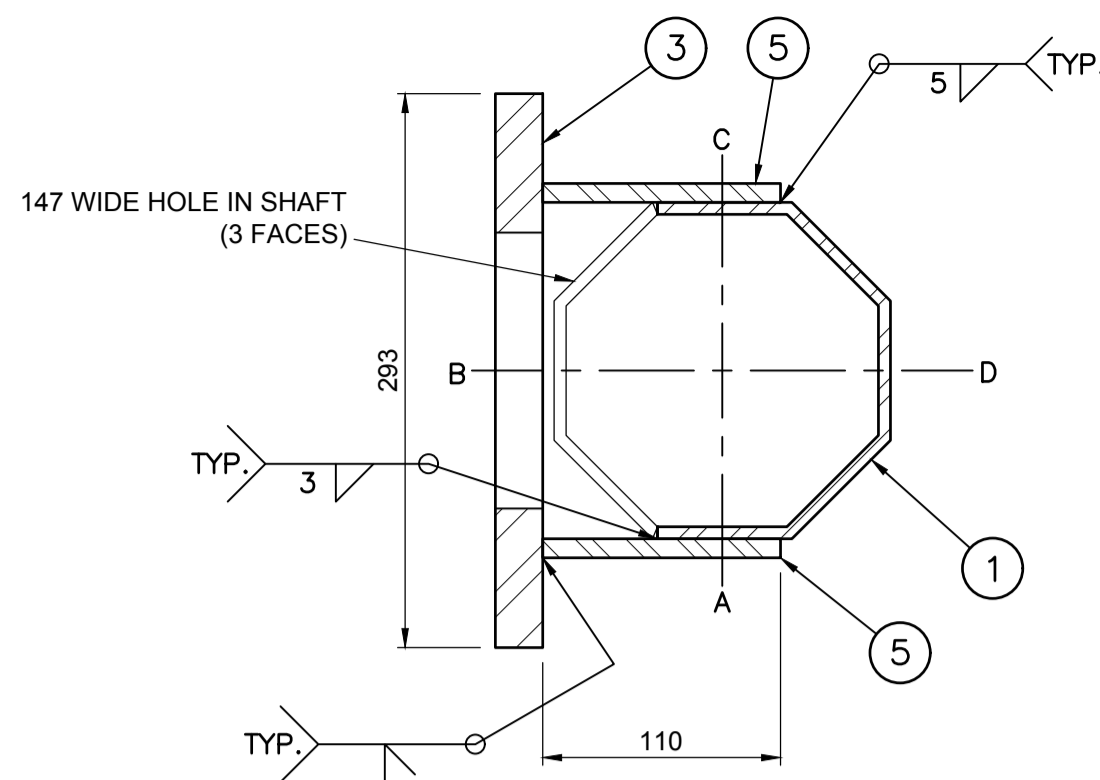

SECTION 2

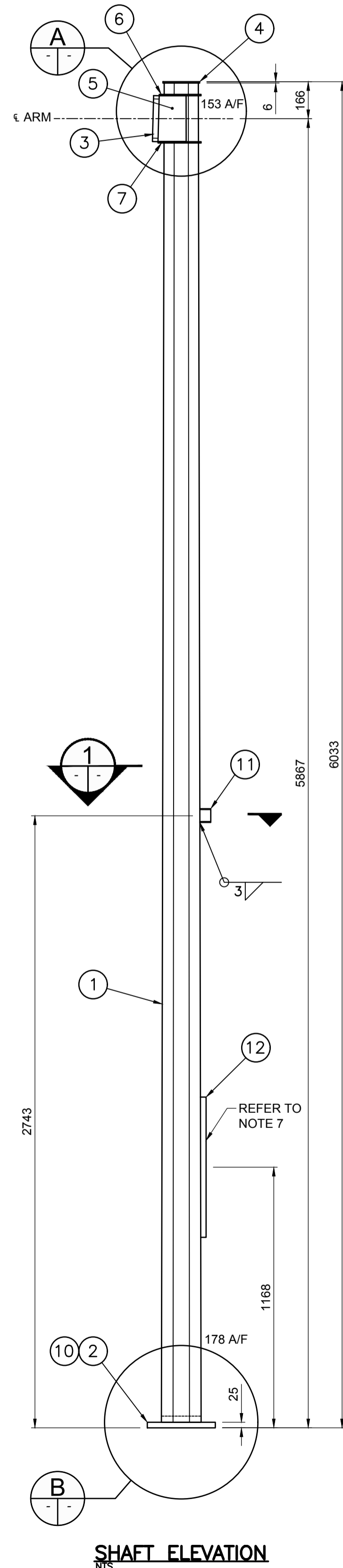

SHAFT ELEVATION

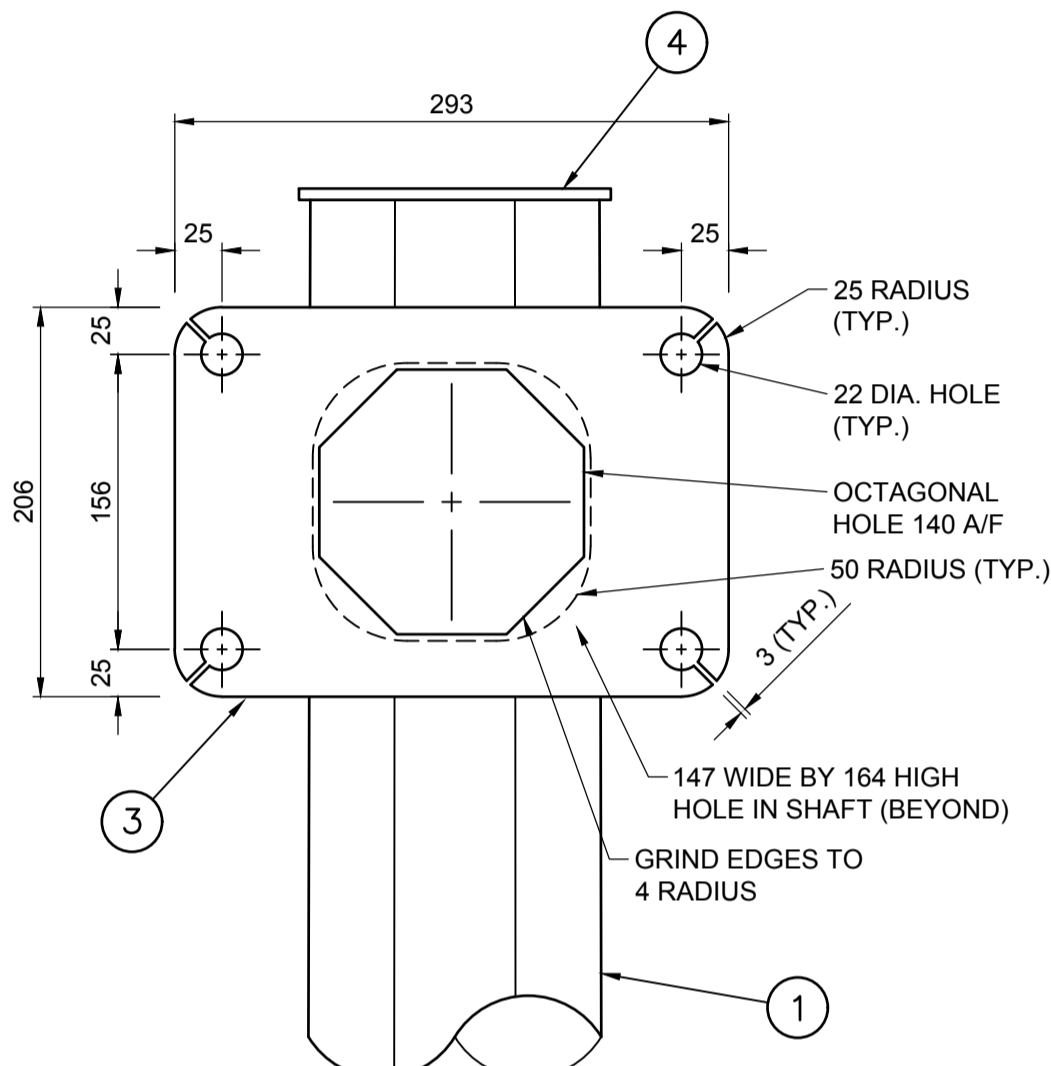

FRONT VIEW

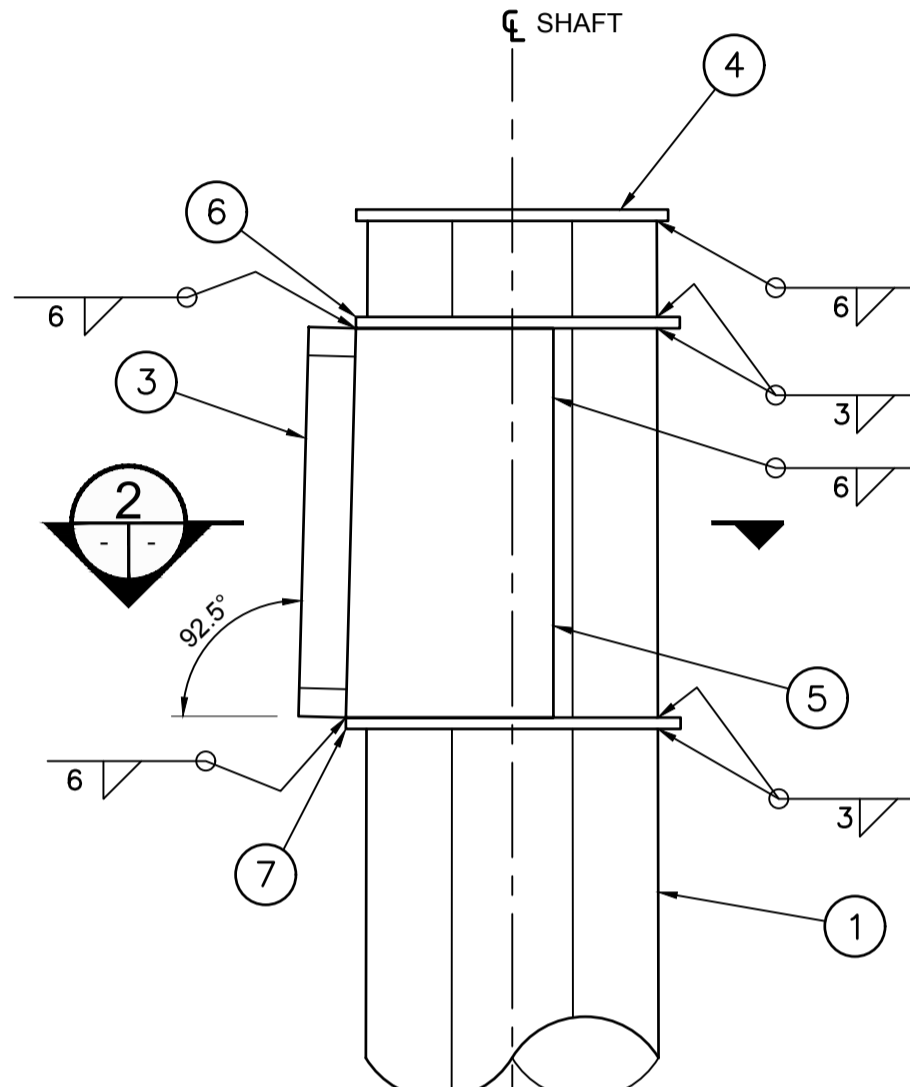

SIDE VIEW

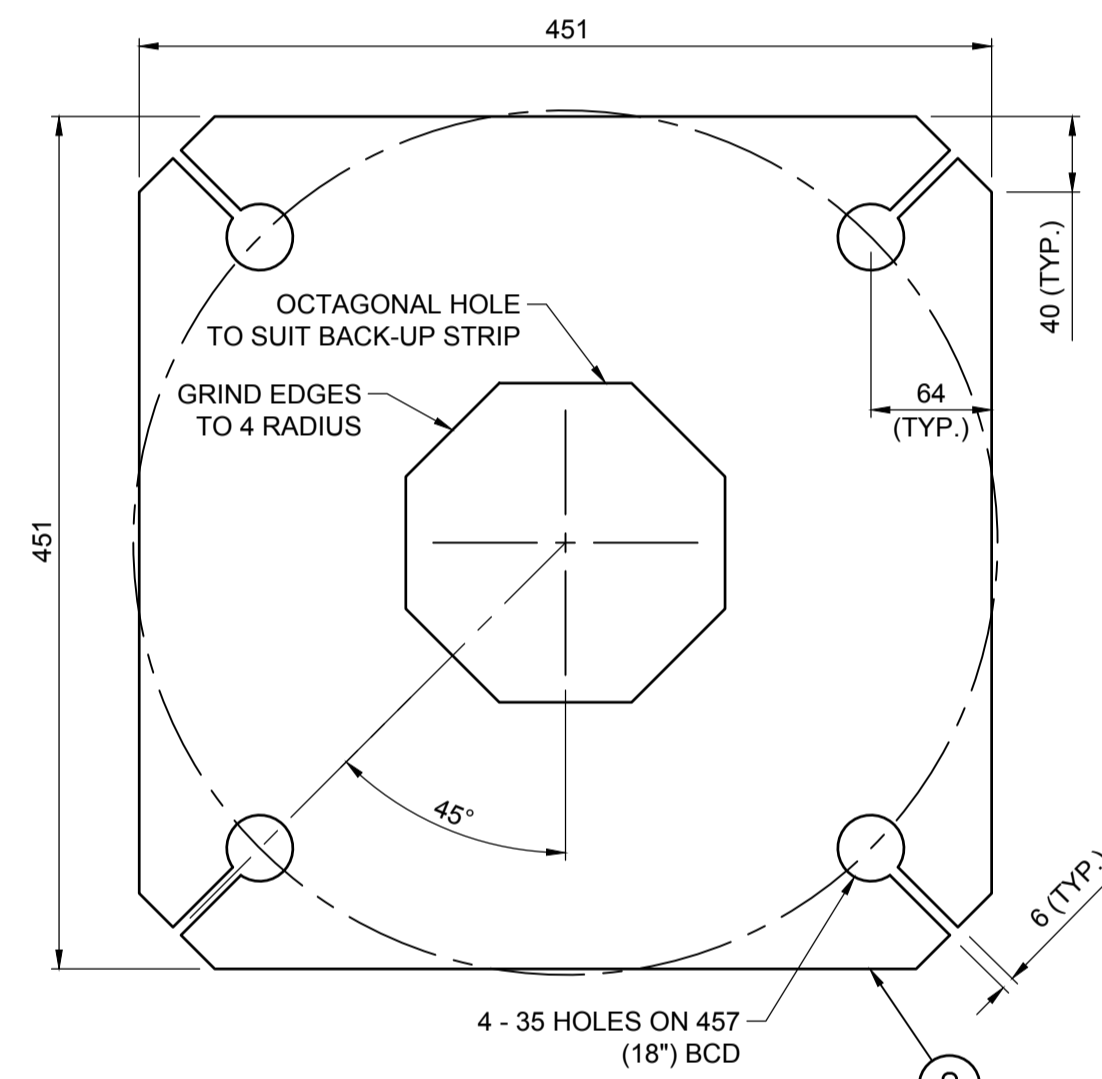

PLAN

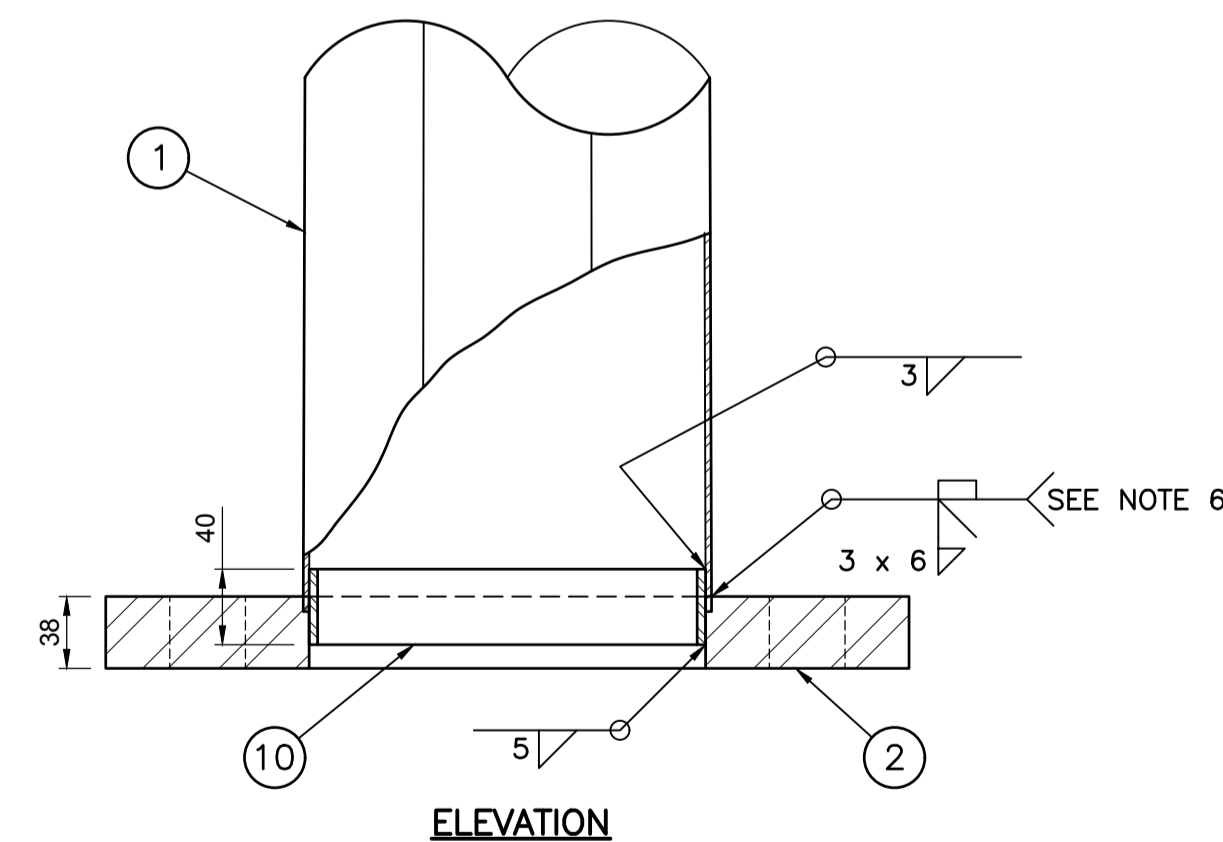

BASE PLATE DETAIL

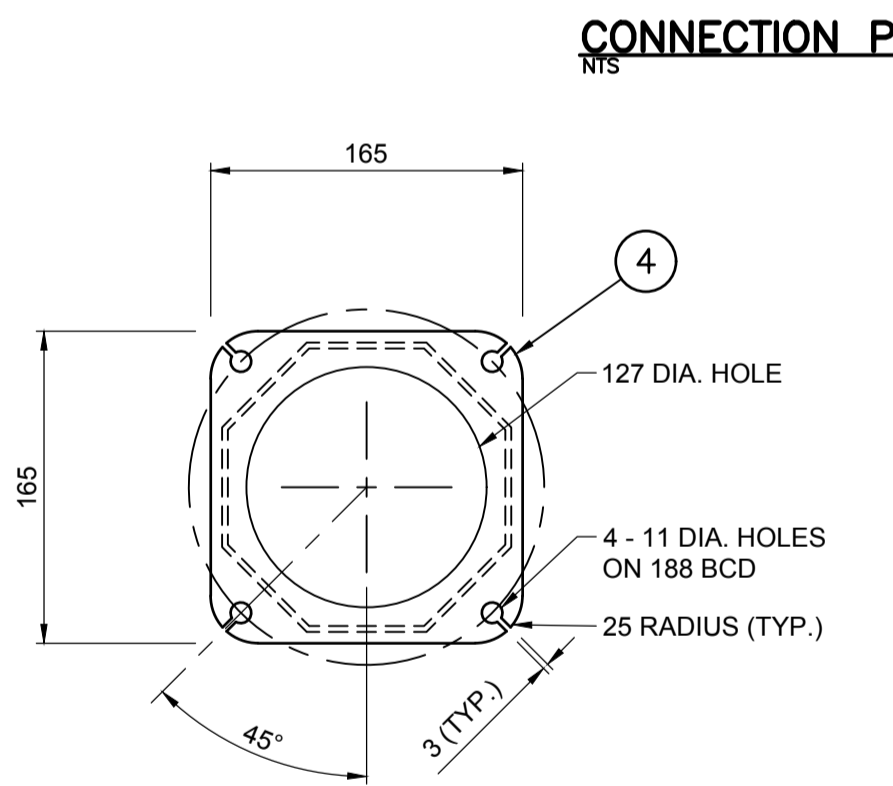

TOP PLATE DETAIL

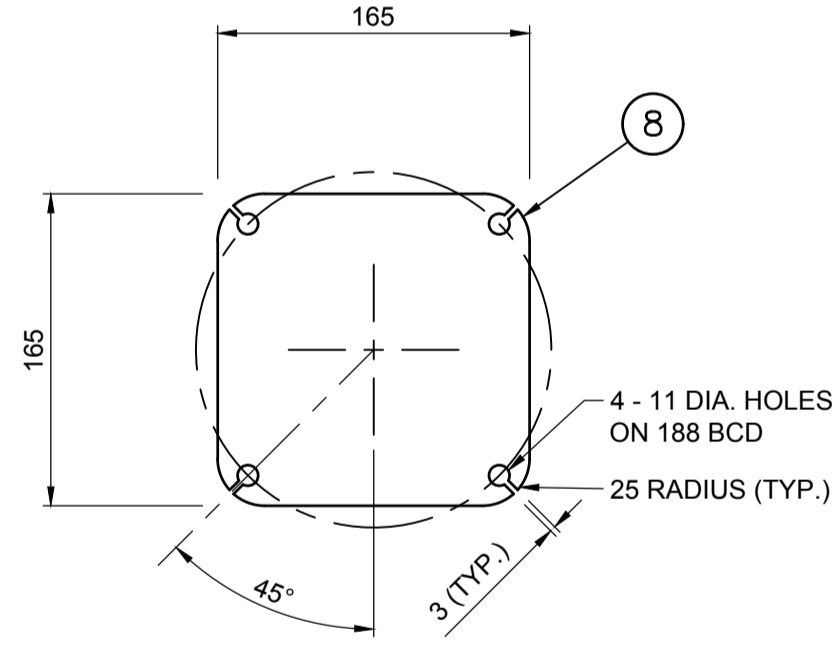

CAP PLATE DETAIL

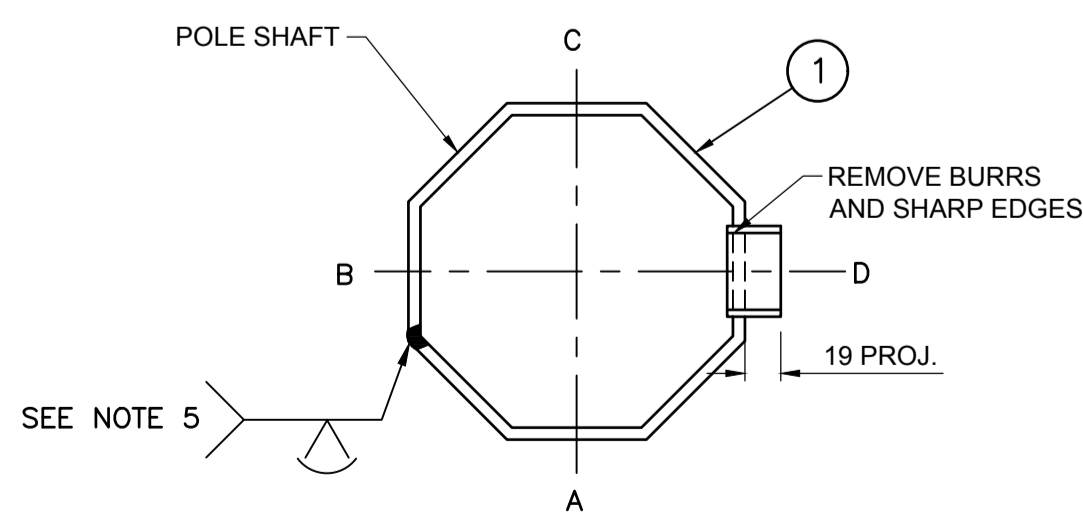

SECTION 1

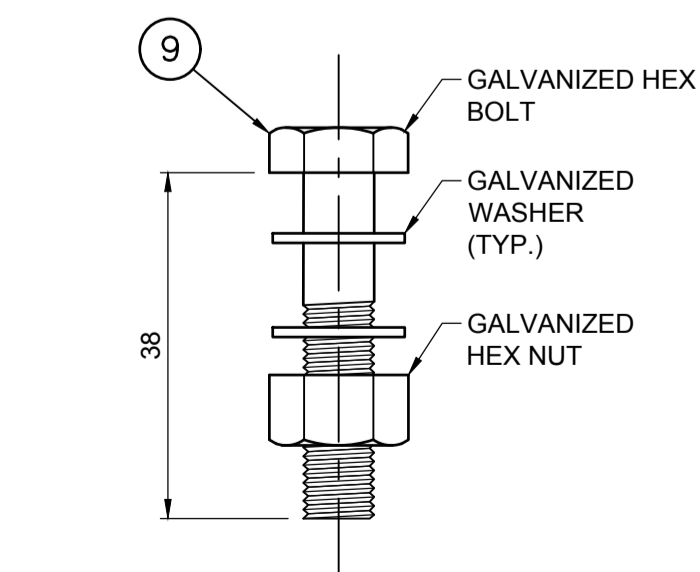

CAP PLATE BOLT DETAIL

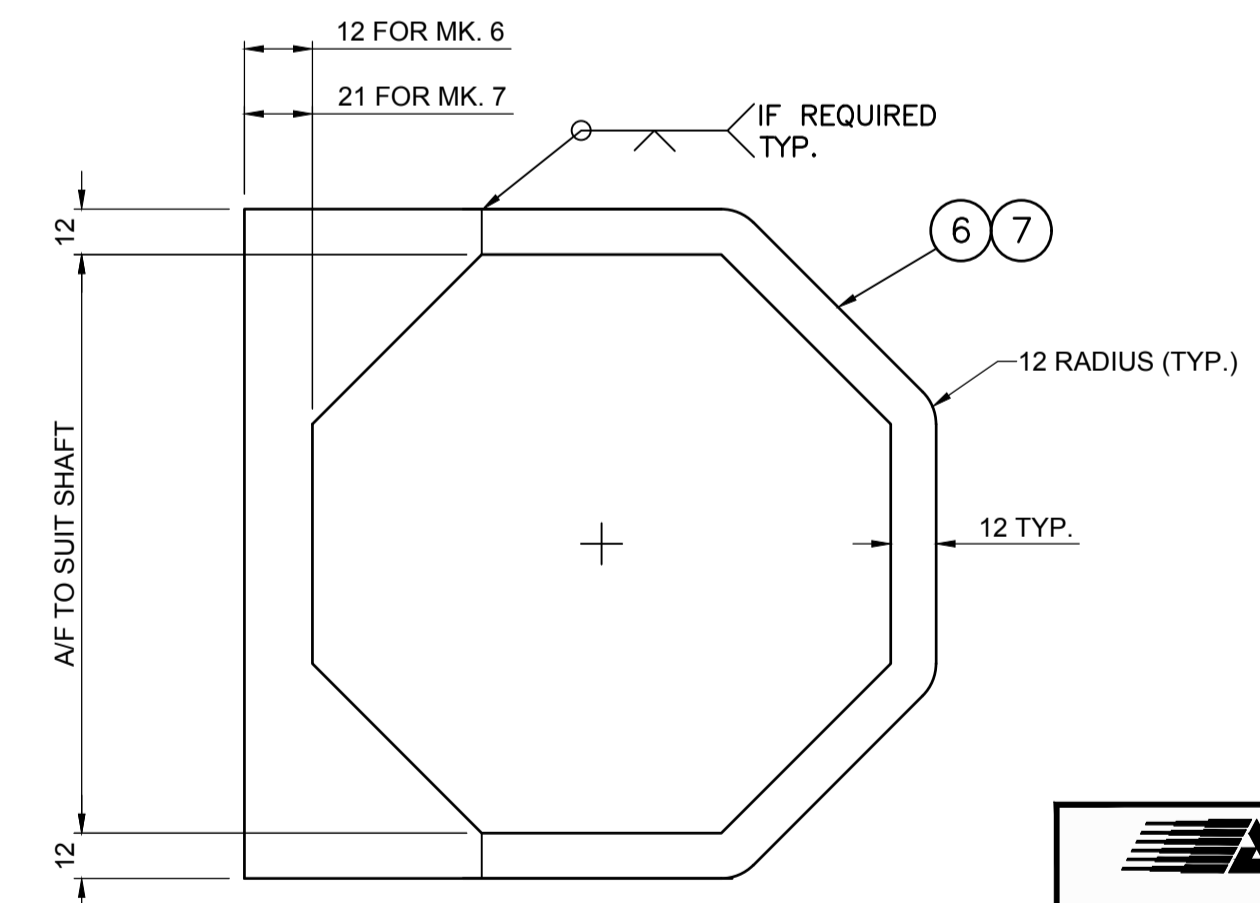

GUSSET PLATE MK. 6 AND MK. 7



REDUCED DRAWING N.T.S.

B.M. ELEV.		DESIGNED BY CDW					
		DRAWN BY JGW				CITY DRAWING NUMBER S-SD-10 SHEET 10 OF 17 CONSULTANT DRAWING NUMBER N/A	
		CHECKED BY SSR		RELEASED FOR CONSTRUCTION DATE	LIGHT DUTY SHAFT		
		APPROVED BY -			CONSULTANT PROJECT NUMBER 12-5954		
4 REVISED BY DILLON CONSULTING 1/10/14 CDW 3 REVISED BY DILLON CONSULTING 8/29/13 CDW 2 REVISED BY DILLON CONSULTING 7/25/13 CDW 1 ISSUED BY DILLON CONSULTING 1/14/13 CDW		HOR. SCALE NTS VERTICAL NTS					
NO. REVISIONS		DATE BY		DATE			